

Daybreak

Homewood Suites



Homewood Suites

Guestroom (A) CP-01



- Product Type: Guest Room
- Style Number: HS103
- Color Number: 130
- Specs: 32 oz. - 12' Width

Homewood Suites

Guestroom (A) CP-01

Manufacturer: Tarkett
Address: 285 Kraft Drive
Dalton, GA 30721
Phone: 706.277.3000
Contact: Jackie Passaro
Jackie.Passaro@tarkett.com
Web: www.tarketthospitality.com

Project Type: Guest Room (A) CP-01
Style Name: HS103
Color: 130
Machine Type: Dynamics
Pattern Repeat: 72" x 58.33"
Width: 12'
Smoke Density: Less Than 450
Fiber Content: 100% C.F. Lextron Enviro-Green
Solution Dyed Nylon
Recycled Content: 10% pre-consumer recycled content
Environmental Information: CRI Green Label Plus™ Certified
Construction: Dynamics Servo Loop Scroll Tip Shear
Gauge: 1/10th
Tufted Pile Weight: 32 oz.
Finished Pile Height: High .250"/Med .187"/Low .062"

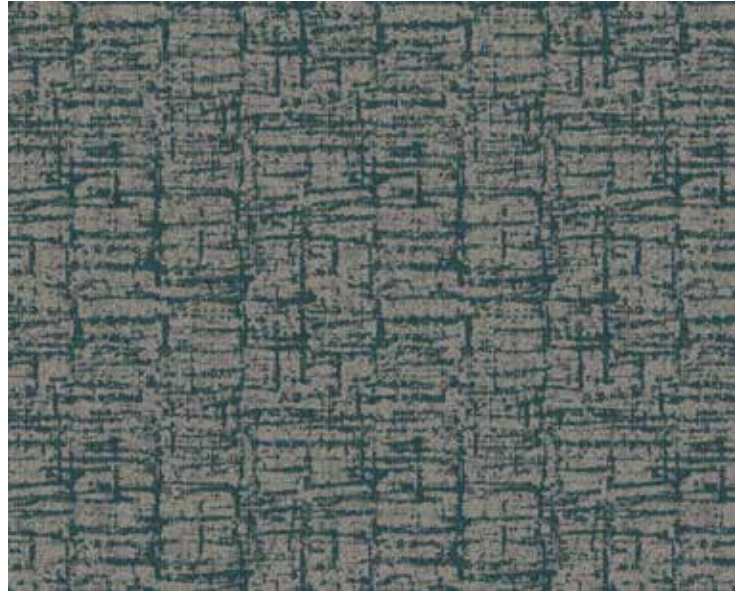

NOTE: Unless Using A Specified Manufacturer, The Following Item(s) are Required to be Submitted for Approval Prior to Fabrication: Finish Sample.

Manufacturer to Confirm the Carpet Meets Hilton Design and Construction Standards as Noted in Section 2514.03.

Glue: Per Manufacturer's Recommendations.

Manufacturer's Recommended Transition Strip: Slim Line Transition

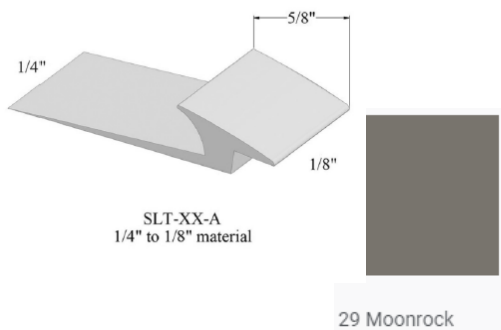

Homewood Suites

Guestroom Carpet Tile (A) CP-01ALT

Manufacturer: Tarkett
Address: 285 Kraft Drive
Dalton, GA 30721
Phone: 706.277.3000
Contact: Jackie Passaro
Jackie.Passaro@tarkett.com
Web: www.tarketthospitality.com

Project Type: Guest Room Carpet Tile (A) CP-01ALT
Style Name: HS51T
Color: 130
Machine Type: Dynamics Tile
Pattern Repeat: 72" x 58.33"
Tile Size: 18" x 36"
Smoke Density: Less Than 450
Fiber Content: 100% C.F. Lextron Enviro-Green
Solution Dyed Nylon
Recycled Content: 10% pre-consumer recycled content
Environmental Information: CRI Green Label Plus™ Certified
Construction: Dynamics Servo Loop Scroll Tip Shear
Gauge: 1/10th
Tufted Pile Weight: 29 oz.
Finished Pile Height: .281"
Secondary Backing: Flex-Aire Modular® Cushion Vertical
Suggested Install: Ashlar/Herringbone Recommended



18" X 36" Random Cut Tile



NOTE: Unless Using A Specified Manufacturer, The Following Item(s) are Required to be Submitted for Approval Prior to Fabrication: Finish Sample.

Manufacturer to Confirm the Carpet Meets Hilton Design and Construction Standards as Noted in Section 2514.03.

Glue: Per Manufacturer's Recommendations.

Manufacturer's Recommended Transition Strip: Slim Line Transition

Install: Vertical Ashlar



Install: Herringbone

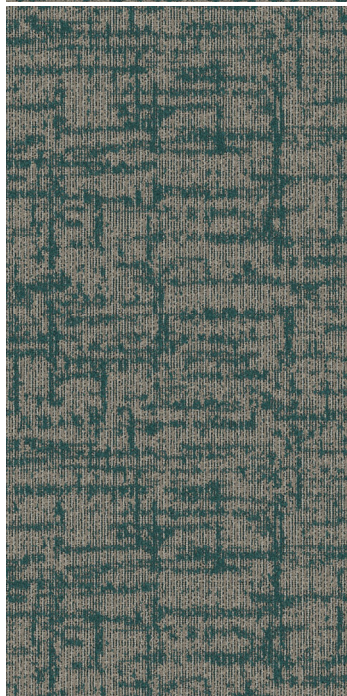
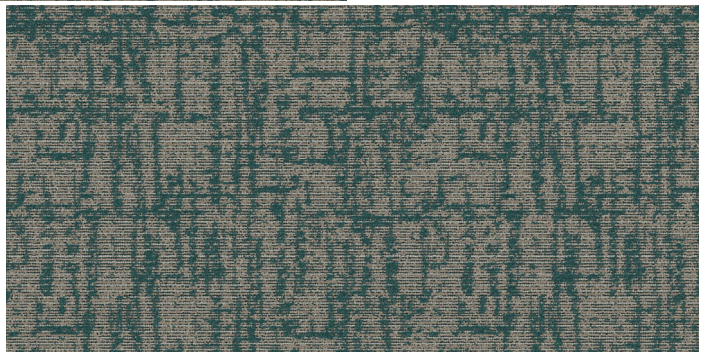
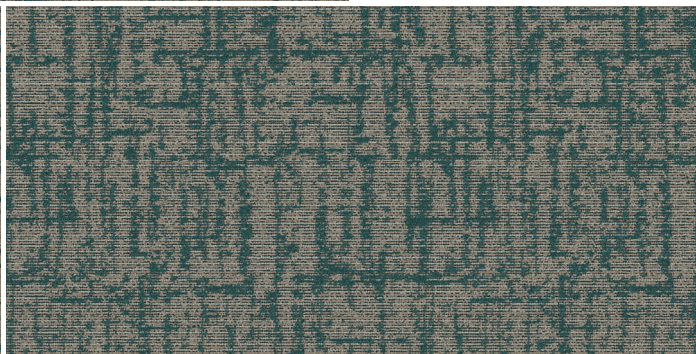
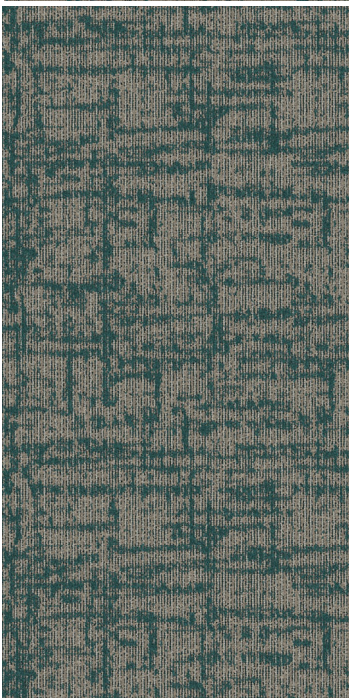
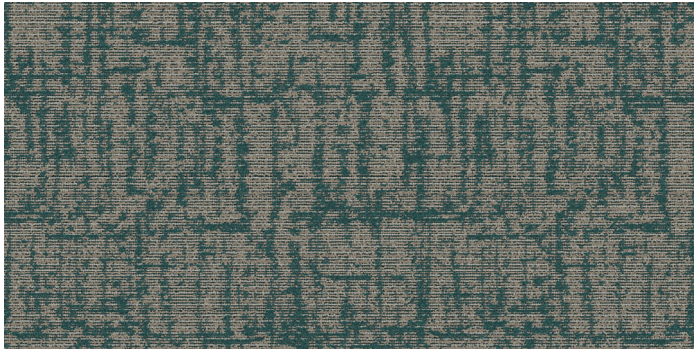

Homewood Suites

Living Room Inset (A) CP-02



- Product Type: Living Room Inset
- Style Number: HS203
- Color Number: 230
- Specs: 32 oz. – 12' Width

Homewood Suites

Living Room Inset (A) CP-02

Manufacturer: Tarkett
Address: 285 Kraft Drive
Dalton, GA 30721
Phone: 706.277.3000
Contact: Jackie Passaro
Jackie.Passaro@tarkett.com
Web: www.tarketthospitality.com

Project Type: Living Room Inset (A) CP-02
Style Name: HS203
Color: 230
Pattern Repeat: 72" x 120"
Width: 12'
Smoke Density: Less Than 450
Fiber Content: 100% C.F. Lextron Enviro-Green Solution Dyed Nylon
Environmental Information: CRI Green Label Plus™ Certified
Construction: Dynamics Multi-Level Loop Tip Shear
Gauge: 1/10th
Tufted Pile Weight: 32 oz.
Finished Pile Height: High .250"/Med .187"/Low .062"

Unless Using A Specified Manufacturer, The Following Item(s) are Required to be Submitted for Approval Prior to Fabrication: Finish Sample.

Manufacturer to Confirm the Carpet Meets Hilton Design and Construction Standards as Noted in Section 2514.03.

Glue: Per Manufacturer's Recommendations.



Homewood Suites

Living Room Inset Carpet Tile (A) CP-02ALT

Manufacturer: Tarkett
Address: 285 Kraft Drive
Dalton, GA 30721
Phone: 706.277.3000
Contact: Jackie Passaro
Jackie.Passaro@tarkett.com
Web: www.tarketthospitality.com

Project Type: Living Room Inset Carpet Tile (A) CP-02ALT
Style Name: HS23T
Color: 230
Pattern Repeat: 72" x 120"
Tile Size: 18" x 36"
Smoke Density: Less Than 450
Fiber Content: 100% C.F. Lextron Enviro-Green Solution Dyed Nylon
Environmental Information: CRI Green Label Plus™ Certified
Construction: Dynamics Multi-Level Loop Tip Shear
Gauge: 1/10th
Tufted Pile Weight: 32 oz.
Finished Pile Height: High .218"/Med .156"/Low .125"
Secondary Backing: Flex-Aire Modular® Cushion
Suggested Install: Vertical Ashlar Recommended



18" X 36" Random Cut Tile



Unless Using A Specified Manufacturer, The Following Item(s) are Required to be Submitted for Approval Prior to Fabrication: Finish Sample.

Manufacturer to Confirm the Carpet Meets Hilton Design and Construction Standards as Noted in Section 2514.03.

Glue: Per Manufacturer's Recommendations.

Suggested install: Vertical Ashlar

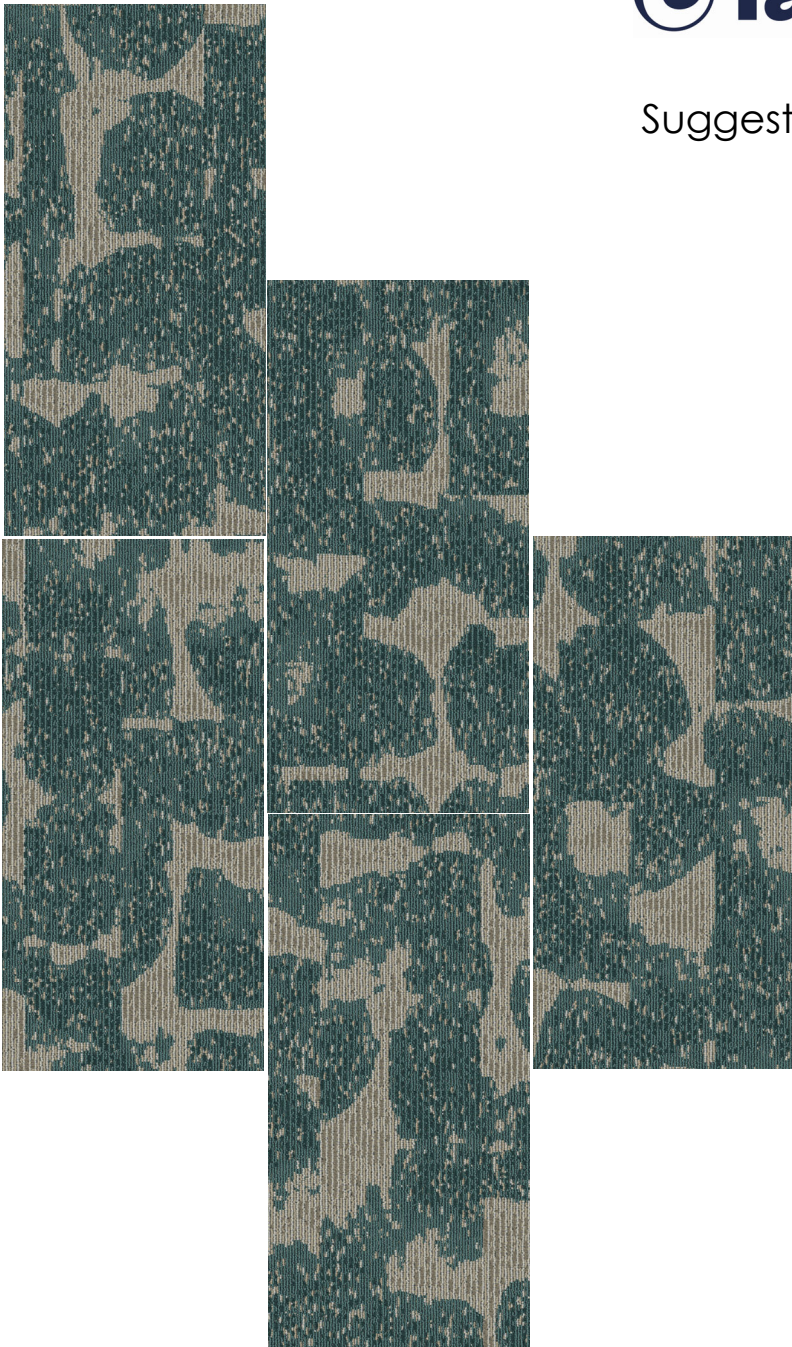

Homewood Suites

Corridor (A) CP-10



- Product Type: Corridor
- Style Number: HS303
- Color Number: 330
- Specs: 36 oz. - 12' Width

Homewood Suites

Corridor (A) CP-10

Manufacturer: Tarkett
Address: 285 Kraft Drive
Dalton, GA 30721
Phone: 706.277.3000
Contact: Jackie Passaro
Jackie.Passaro@tarkett.com
Web: www.tarketthospitality.com

Project Type: Corridor (A) CP-10
Style Name: HS303
Color: 330
Pattern Repeat: 72" x 53.71"
Width: 12'
Smoke Density: Less Than 450
Fiber Content: 100% C.F. Lextron Enviro-Green Solution Dyed Nylon
Environmental Information: CRI Green Label Plus™ Certified
Construction: Intrepid Multi-Level Loop Tip Shear
Gauge: 1/10th
Tufted Pile Weight: 36 oz.
Finished Pile Height: High .250"/Med .187"/Low .062"

Notes:

For 15' Width refer to A CP-10 (ALT)

Style: HS310 Color: 330

Repeat: 90"W x 53.71"L

Repeat Type: Side Match

Product Type; Intrepid

Ounce Weight: 36 oz.

Unless Using A Specified Manufacturer, The Following Item(s) are Required to be Submitted for Approval Prior to Fabrication: Finish Sample.

Manufacturer to Confirm the Carpet Meets Hilton Design and Construction Standards as Noted in Section 2514.03.

Glue: Per Manufacturer's Recommendations.



Homewood Suites

Corridor Carpet Tile (A) CP-10ALT

Manufacturer: Tarkett
Address: 285 Kraft Drive
Dalton, GA 30721
Phone: 706.277.3000
Contact: Jackie Passaro
Jackie.Passaro@tarkett.com
Web: www.tarketthospitality.com

Project Type: Corridor Carpet Tile (A) CP-10ALT
Style Name: HS43T
Color: 243
Pattern Repeat: 76" x 53.71"
Tile Size: 18" x 36"
Smoke Density: Less Than 450
Fiber Content: 100% C.F. Lextron Enviro-Green Solution Dyed Nylon
Environmental Information: CRI Green Label Plus™ Certified
Construction: Intrepid Multi-Level Loop Tip Shear
Gauge: 1/10th
Tufted Pile Weight: 36 oz.
Finished Pile Height: High .218"/Low .174" (Approx.)
Secondary Backing: Flex-Aire Modular® Cushion
Install Method: Vertical Ashlar Recommended

Notes:

Unless Using A Specified Manufacturer, The Following Item(s) are Required to be Submitted for Approval Prior to Fabrication: Finish Sample.

Manufacturer to Confirm the Carpet Meets Hilton Design and Construction Standards as Noted in Section 2514.03.

Glue: Per Manufacturer's Recommendations.



18' X 36" Random Cut Tile



Suggested install: Vertical Ashlar



Homewood Suites

Social Nook & Living Room (A) CP-11



- Product Type: Social Nook & Living Room
- Style Number: HS403
- Color Number: 430
- Specs: 36 oz. - 12' Width

Homewood Suites

Social Nook & Living Room A CP-11

Manufacturer: Tarkett
Address: 285 Kraft Drive
Dalton, GA 30721
Phone: 706.277.3000
Contact: Jackie Passaro
Jackie.Passaro@tarkett.com
Web: www.tarketthospitality.com

Project Type: Social Nook & Living Room (A) CP-11
Style Name: HS403
Color: 430
Pattern Repeat: 72" x 75.42"
Width: 12'
Smoke Density: Less Than 450
Fiber Content: 100% C.F. Lextron Enviro-Green Solution Dyed Nylon
Environmental Information: CRI Green Label Plus™ Certified
Construction: Intrepid Multi-Level Loop Tip Shear
Gauge: 1/10th
Tufted Pile Weight: 36 oz.
Finished Pile Height: High .250"/Med .187"/Low .062"



Unless Using A Specified Manufacturer, The Following Item(s) are Required to be Submitted for Approval Prior to Fabrication: Finish Sample.

Manufacturer to Confirm the Carpet Meets Hilton Design and Construction Standards as Noted in Section 2514.03.

Glue: Per Manufacturer's Recommendations.

Homewood Suites

Social Nook & Living Room Carpet Tile (A) CP-11ALT

Manufacturer: Tarkett
Address: 285 Kraft Drive
Dalton, GA 30721
Phone: 706.277.3000
Contact: Jackie Passaro
Jackie.Passaro@tarkett.com
Web: www.tarkethospitality.com

Project Type: Social Nook & Living Room Carpet Tile (A) CP-11ALT
Style Name: HS49T
Color: 430
Pattern Repeat: 76" x 74.29"
Tile Size: 18" x 36"
Smoke Density: Less Than 450
Fiber Content: 100% C.F. Lextron Enviro-Green Solution Dyed Nylon
Environmental Information: CRI Green Label Plus™ Certified
Construction: Intrepid Multi-Level Loop Tip Shear
Gauge: 1/10th
Tufted Pile Weight: 26 oz.
Finished Pile Height: High .218"/Med .125"/Low .0625"
Secondary Backing: Flex-Aire Modular® Cushion
Install Method: Vertical Ashlar Recommended



18" x 36" Random Cut Tile

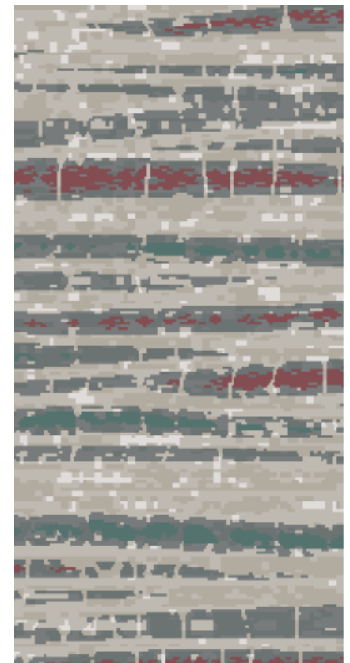

Unless Using A Specified Manufacturer, The Following Item(s) are Required to be Submitted for Approval Prior to Fabrication: Finish Sample.

Manufacturer to Confirm the Carpet Meets Hilton Design and Construction Standards as Noted in Section 2514.03.

Glue: Per Manufacturer's Recommendations.

Suggested Install Method: Ashlar

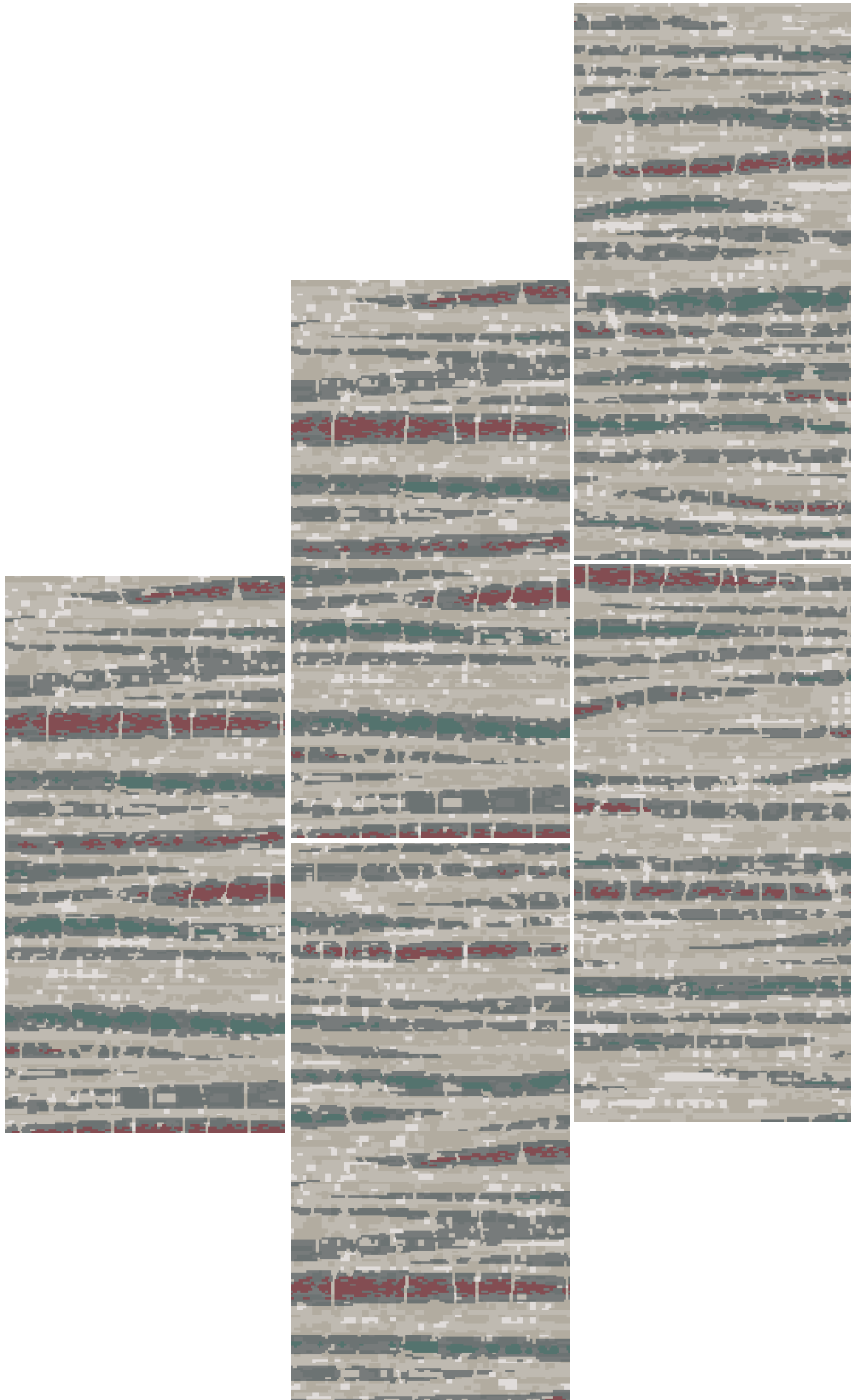

Homewood Suites

Central Hub & Dining Room A CP-12



- Product Type: Central Hub & Dining Room
- Style Number: HS503
- Color Number: 530
- Specs: 36 oz. - 12' Width

Homewood Suites

Central Hub & Dining Room (A) CP-12

Manufacturer: Tarkett
Address: 285 Kraft Drive
Dalton, GA 30721
Phone: 706.277.3000
Contact: Jackie Passaro
Jackie.Passaro@tarkett.com
Web: www.tarketthospitality.com

Project Type: Central Hub & Dining Room (A) CP-12
Style Name: HS503
Color: 530
Pattern Repeat: 144" x 205.71"
Width: 12'
Smoke Density: Less Than 450
Fiber Content: 100% C.F. Lextron Enviro-Green Solution Dyed Nylon
Environmental Information: CRI Green Label Plus™ Certified
Construction: Intrepid Multi-Level Loop Tip Shear
Gauge: 1/10th
Tufted Pile Weight: 36 oz.
Finished Pile Height: High .250"/Med .187"/Low .062"

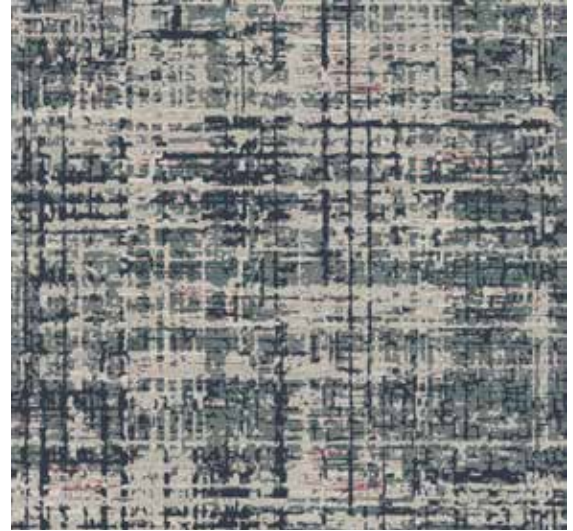

Unless Using A Specified Manufacturer, The Following Item(s) are Required to be Submitted for Approval Prior to Fabrication: Finish Sample.

Manufacturer to Confirm the Carpet Meets Hilton Design and Construction Standards as Noted in Section 2514.03.

Glue: Per Manufacturer's Recommendations.

Homewood Suites

Central Hub & Dining Room Carpet Tile (A) CP-12

Manufacturer: Tarkett
Address: 285 Kraft Drive
Dalton, GA 30721
Phone: 706.277.3000
Contact: Jackie Passaro
Jackie.Passaro@tarkett.com
Web: www.tarketthospitality.com

Project Type: Central Hub & Dining Room Carpet Tile (A) CP-12ALT
Style Name: HS57T
Color: 527
Pattern Repeat: 76.00" X 205.71"
Tile Size: 18" x 36"
Smoke Density: Less Than 450
Fiber Content: 100% C.F. Lextron Enviro-Green Solution Dyed Nylon
Environmental Information: CRI Green Label Plus™ Certified
Construction: Intrepid Multi-Level Loop Tip Shear
Gauge: 1/10th
Tufted Pile Weight: 32 oz.
Finished Pile Height: High .281"
Secondary Backing: Flex-Aire Modular® Cushion
Install Method: Vertical Ashlar Recommended

Unless Using A Specified Manufacturer, The Following Item(s) are Required to be Submitted for Approval Prior to Fabrication: Finish Sample.

Manufacturer to Confirm the Carpet Meets Hilton Design and Construction Standards as Noted in Section 2514.03.

Glue: Per Manufacturer's Recommendations.

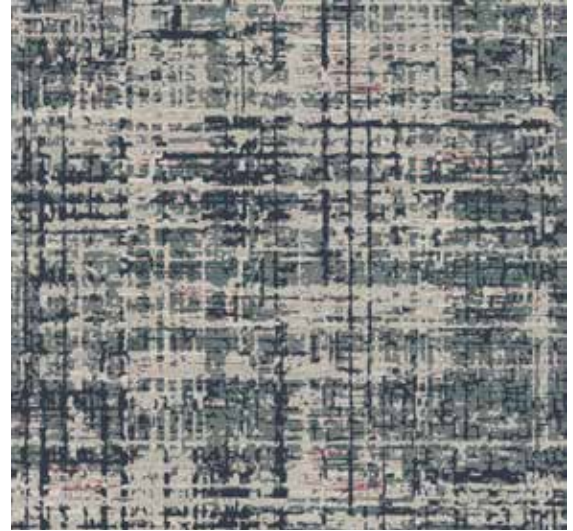

18" X 36" Random Cut Tile



Install: Vertical Ashlar



Install: Herringbone

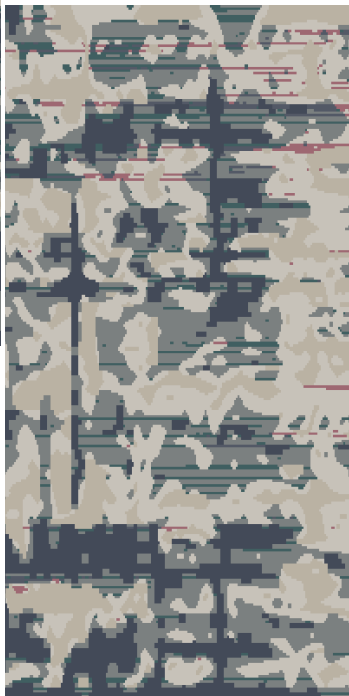
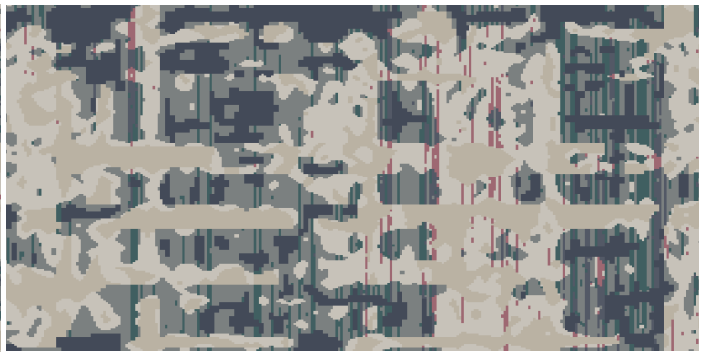
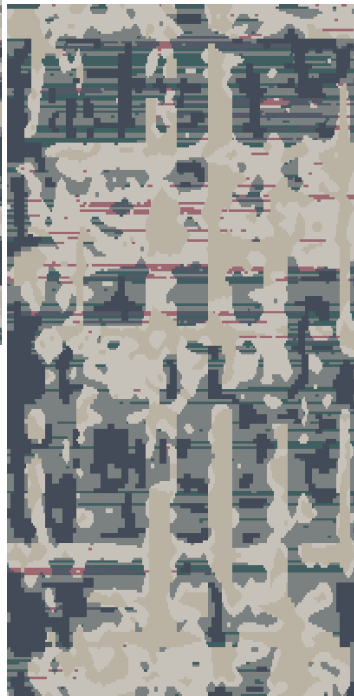
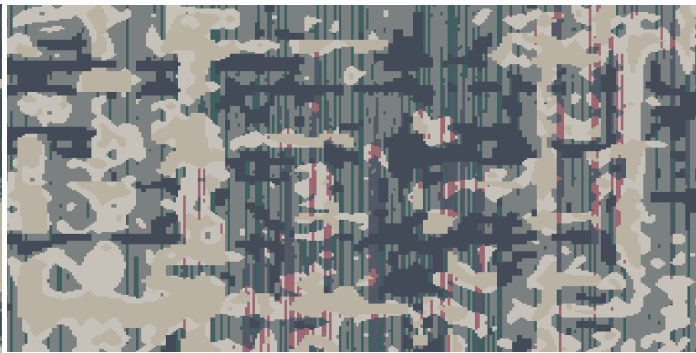
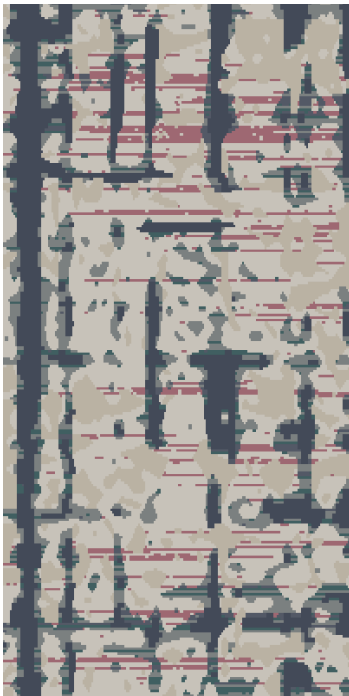
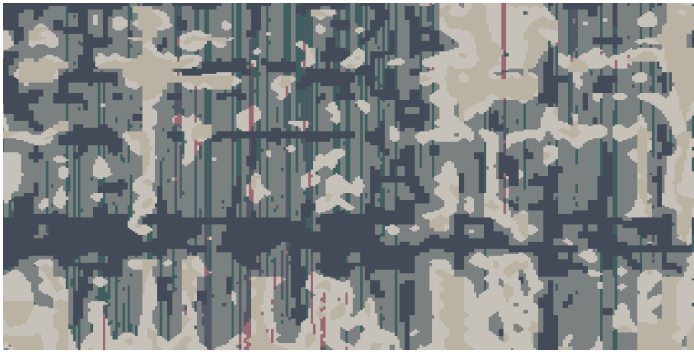

Homewood Suites

Carpet at Meeting Room (A) CP-13

Manufacturer: Tarkett
Address: 285 Kraft Drive
Dalton, GA 30721
Phone: 706.277.3000
Contact: Jackie Passaro
Jackie.Passaro@tarkett.com
Web: www.tarketthospitality.com

Project Type: Carpet at Meeting Room (A) CP-13
Style Name: HS603
Color: 630
Pattern Repeat: 90"W x 130.29"L
Width: 15'
Smoke Density: Less Than 450
Fiber Content: 100% C.F. Lextron Enviro-Green Solution Dyed Nylon
Environmental Information: CRI Green Label Plus™ Certified
Construction: Intrepid Multi-Level Loop Tip Shear
Gauge: 1/10th
Tufted Pile Weight: 36 oz.
Finished Pile Height: High .250"/Med .187"/Low .062"

Unless Using A Specified Manufacturer, The Following Item(s) are Required to be Submitted for Approval Prior to Fabrication: Finish Sample.

Manufacturer to Confirm the Carpet Meets Hilton Design and Construction Standards as Noted in Section 2514.03.

Glue: Per Manufacturer's Recommendations.



Homewood Suites

Carpet Tile at Meeting Room (A) CP-13ALT

Manufacturer: Tarkett
Address: 285 Kraft Drive
Dalton, GA 30721
Phone: 706.277.3000
Contact: Jackie Passaro
Jackie.Passaro@tarkett.com
Web: www.tarkethospitality.com

Project Type: Carpet Tile at Meeting Room (A) CP-13ALT
Style Name: HS63T
Color: 185
Tile Size: 24"W x 24"L
Smoke Density: Less Than 450
Fiber Content: 100% C.F. Lextron Enviro-Green Solution Dyed Nylon
Environmental Information: CRI Green Label Plus™ Certified
Construction: Intrepid Multi-Level Loop Tip Shear
Gauge: 1/10th
Tufted Pile Weight: 32 oz.
Finished Pile Height: 220 in approx.
Install Method: Vertical Ashlar or Quarter Turn

Unless Using A Specified Manufacturer, The Following Item(s) are Required to be Submitted for Approval Prior to Fabrication: Finish Sample.

Manufacturer to Confirm the Carpet Meets Hilton Design and Construction Standards as Noted in Section 2514.03.

Glue: Per Manufacturer's Recommendations.



24" X 24" Random Cut Tile

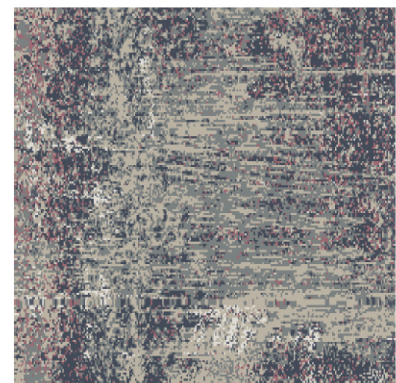

Install: Vertical Ashlar

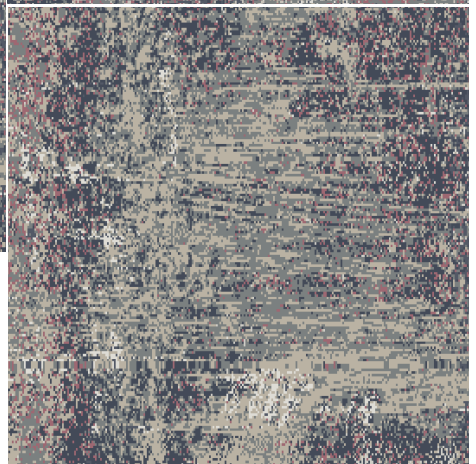
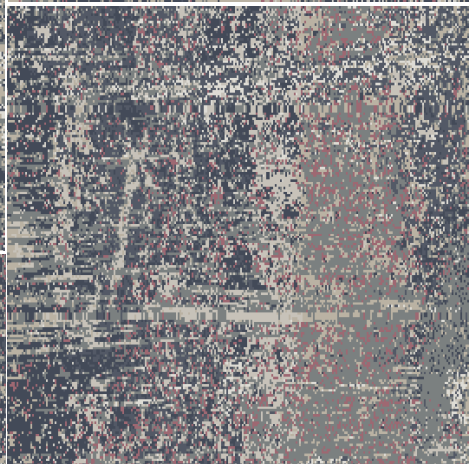
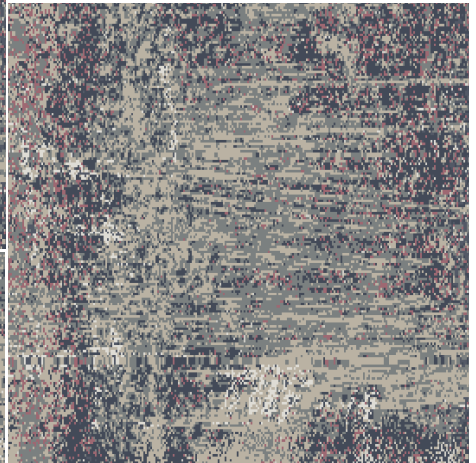
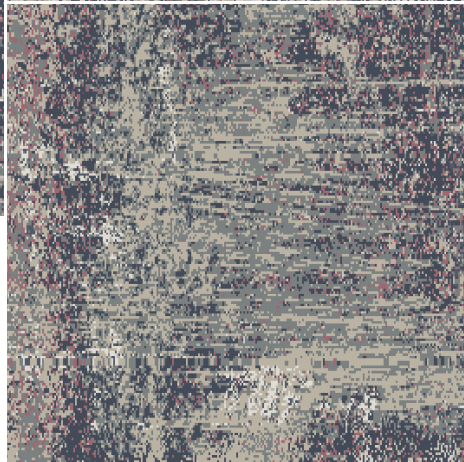
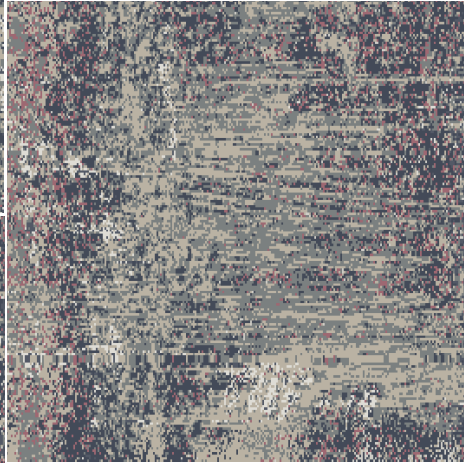
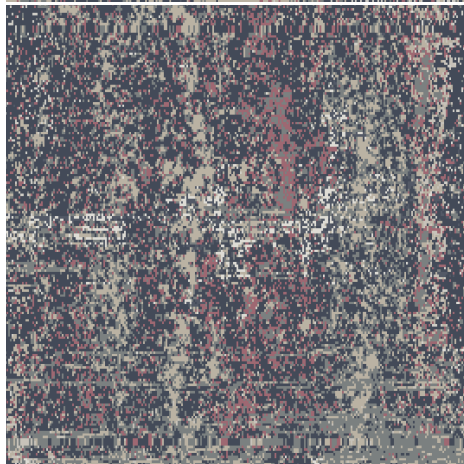
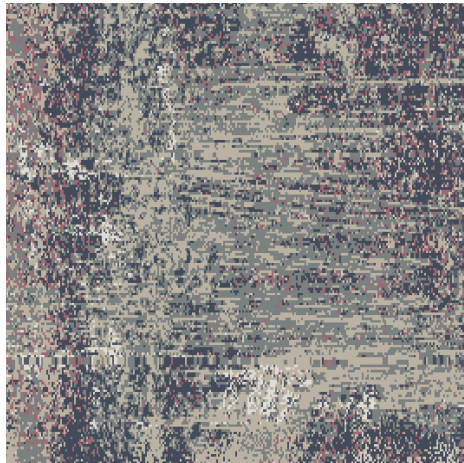

Install: Quarter Turn

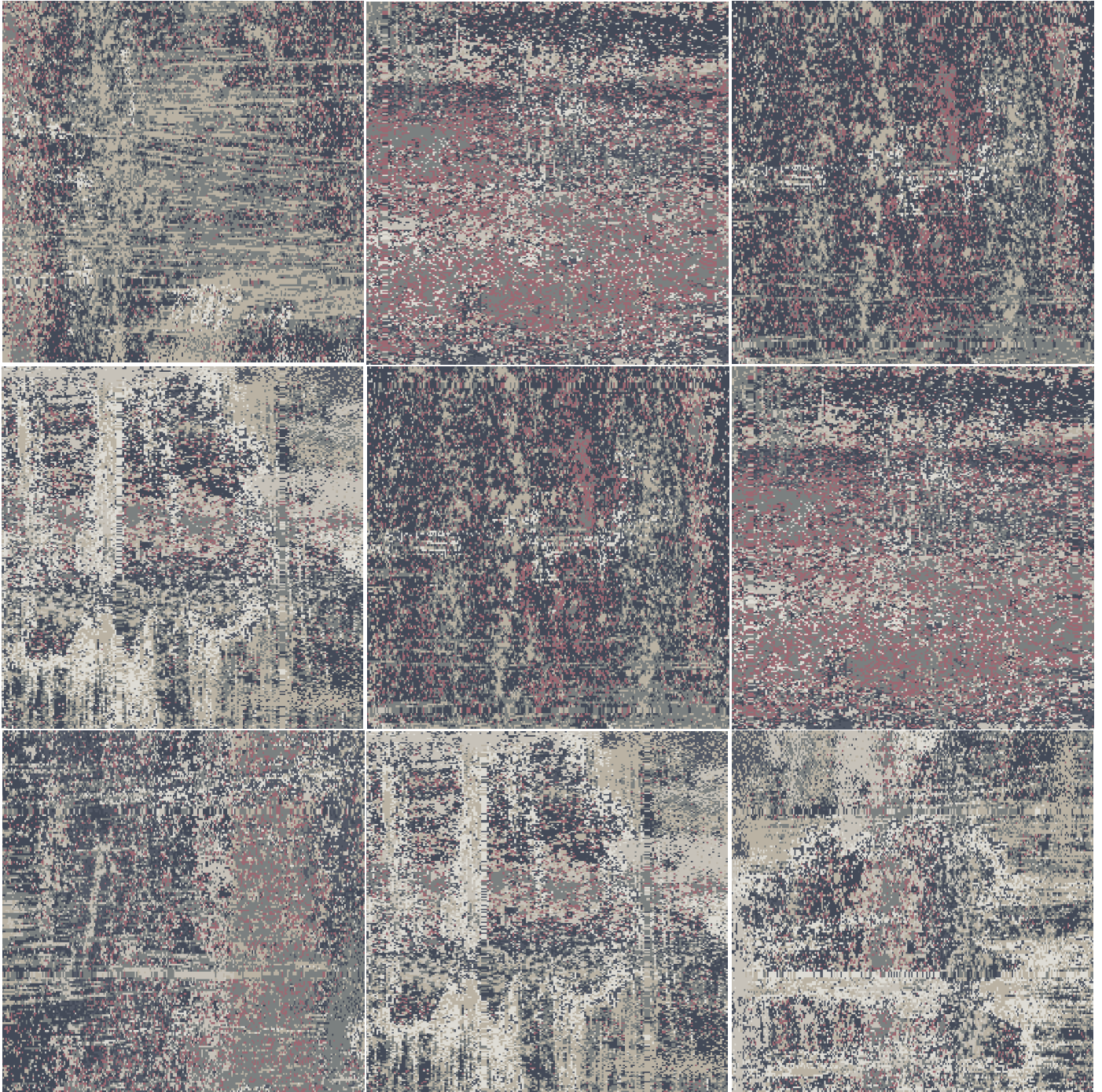

Homewood Suites

Luxury Vinyl Tile (A) RES-01



- Product Type: Luxury Vinyl Tile
- Style Number: ACCOR-0023-7X48-VT
- Specs: 7" x 48" - 0.197" (5mm)

Homewood Suites

Luxury Vinyl Tile (A) RES-01

Manufacturer: Tarkett
Address: 285 Kraft Drive
Dalton, GA 30721
Phone: 706.277.3000
Contact: Jackie Passaro
Jackie.Passaro@tarkett.com
Web: www.tarkethospitality.com

Product Type: Enhanced Resilient Tile (A) RES-01
Style Name: Accore Waterproof Rigid Core SPC Plank
Style/Color: ACCOR-0023-7X48-VT
Plank Size: 7" x 48" Plank
Nominal Thickness: 5 mm
Core Thickness: 4 mm
Accoustical Backing: 1mm IXPE
Impact Sound Rating: 68
Wearlayer Thickness: 20 mil
Edge Treatment: Micro-bevel
Installation: Click, Drop Lock System
Carton Size: 23.64SF (10 planks per carton)

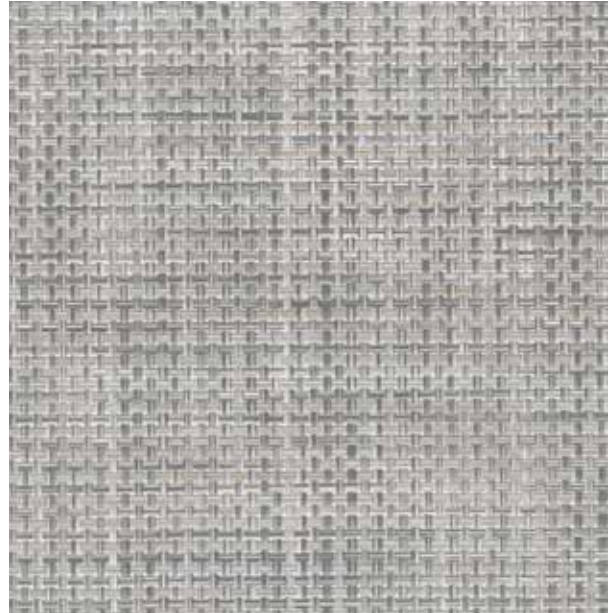

** Accore will be carried as a "stocking" item - US Warehouse

For installation instructions, warranty, maintenance and technical services, visit www.tarkett.com or contact Tarkett at (888) 639-8297.



CERTIFIED BY
SCS Global Services



CERTIFIED BY
SCS Global Services

Homewood Suites

Resilient Wall Base

(A) RB-01
Area: Guestroom
Product Type: Monument 4" Wall Base
Style Number: MW-27-S4
Specs: 4"H x 0.25"D x 8'L
Color Number: 27 Mist

(A) RB-10
Area: Corridor
Product Type: Monument 4" Wall Base
Style Number: MW-24-S4
Specs: 4"H x 0.25"D x 8'L
Color Number: 24 Grey Haze

(A) RB-11
Area: Fitness
Product Type: Monument 4" Wall Base Style
Number: MW-48-S4
Specs: 4"H x 0.25"D x 8'L
Color Number: 48 Grey



Daybreak Suite Layout

Homewood Suites



No printed material contained here-in may be reproduced without the written permission of Tarkett, Inc.
Due to variations in monitors and light sources, we cannot guarantee that the colors in this image will be an exact match to your colors.
Tarkett Hospitality 285 Kraft Dr. Dalton GA 30721